



HEAVY DUTY

STAIR CLIMBER

The Stair Climber is a cutting-edge solution for effortlessly transporting heavy items up and down stairs. Engineered with powerful motorized assistance and ergonomic design, it ensures safety, efficiency, and ease of use in any environment, from homes to commercial spaces. Elevate your moving experience with unmatched convenience and reliability.



Easy Maintenance



Non-Slip Wheels



High Load Capacity



Lightweight and Durable

TABLE OF CONTENT

01	HPS216L-200	06	HB247-60
02	HPS203L-180	07	HBS201-200
03	HPS202H-180	08	HPST201-200
04	HPS215X-180	09	HPB203A
05	HPS231-60	10	HGC203C
		11	HB203B

STAIR CLIMBER POWERED

TYPE HPS216L-200

Effortlessly transport heavy items with the motorized Stair Climber, offering smooth, safe, and efficient operation for commercial and industrial use. Features include strong motor assistance, non-slip wheels, and a reliable braking system.

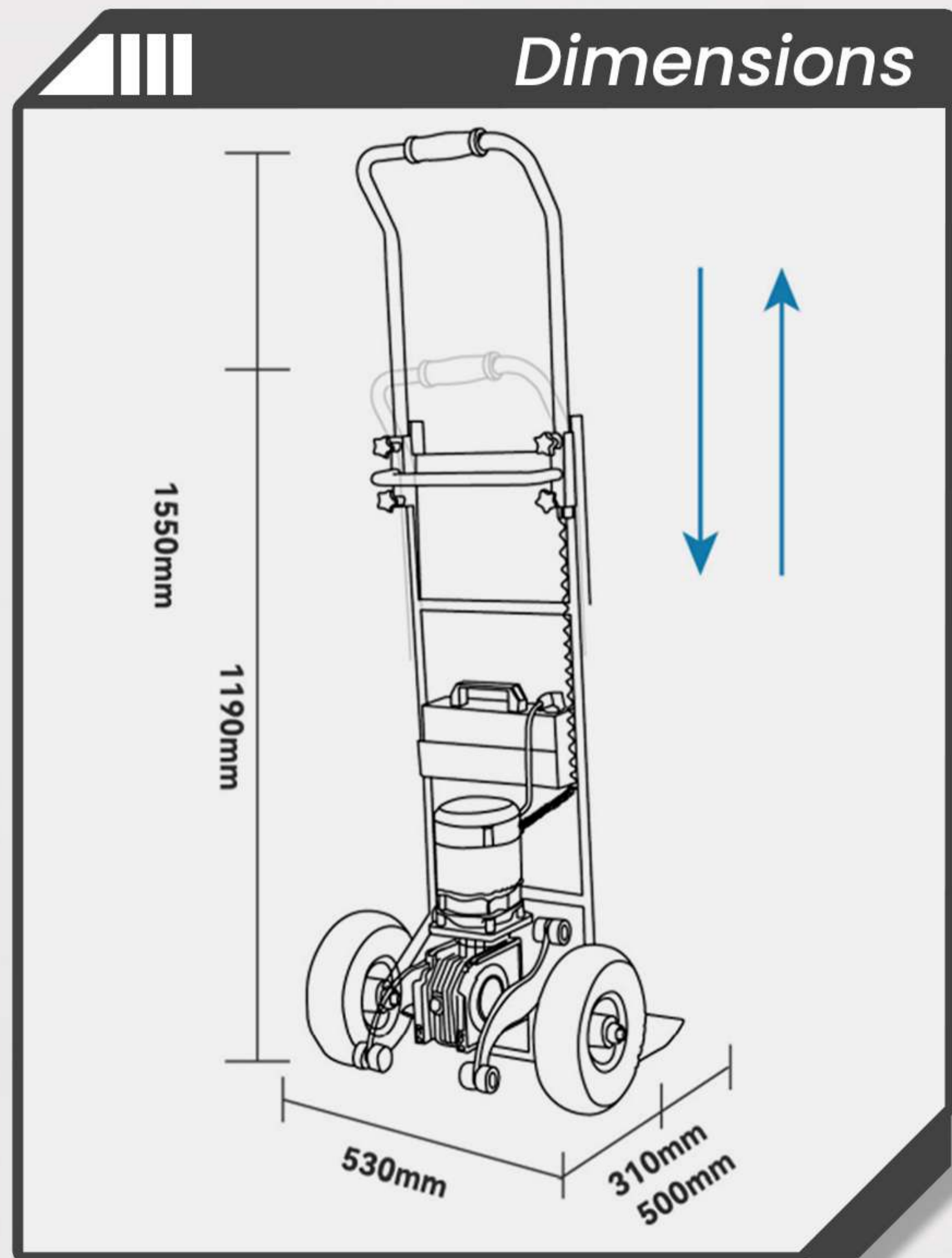

High Load
Capacity



Non-Slip
Wheels



Lightweight
And Durable

SPECIFICATION

Body material	Steel	Battery capacity	8AH
Product weight	35kg	Endurance	1400 steps (continuous climbing with full load)
Battery weight	3kg	Handrail style	Scalable
Maximum load	250kg	Main wheel	10 inches
MAX climbing speed	45step/min	Maximum step height	230mm
Working voltage	48VDC	Minimum turning radius	500mm
Charging voltage	220VAC	Noise	<80db
Charging time	3H	Working ambient temperature	From -20°C to 50°C
Motor type	500W	Maximum size	1550*500*530mm
Battery type	Lithium battery	Minimum size	1190*500*310mm

STAIR CLIMBER POWERED

TYPE HPS203L-180

Effortlessly transport heavy items with the motorized Stair Climber, offering smooth, safe, and efficient operation for commercial and industrial use. Features include strong motor assistance, non-slip wheels, and a reliable braking system.

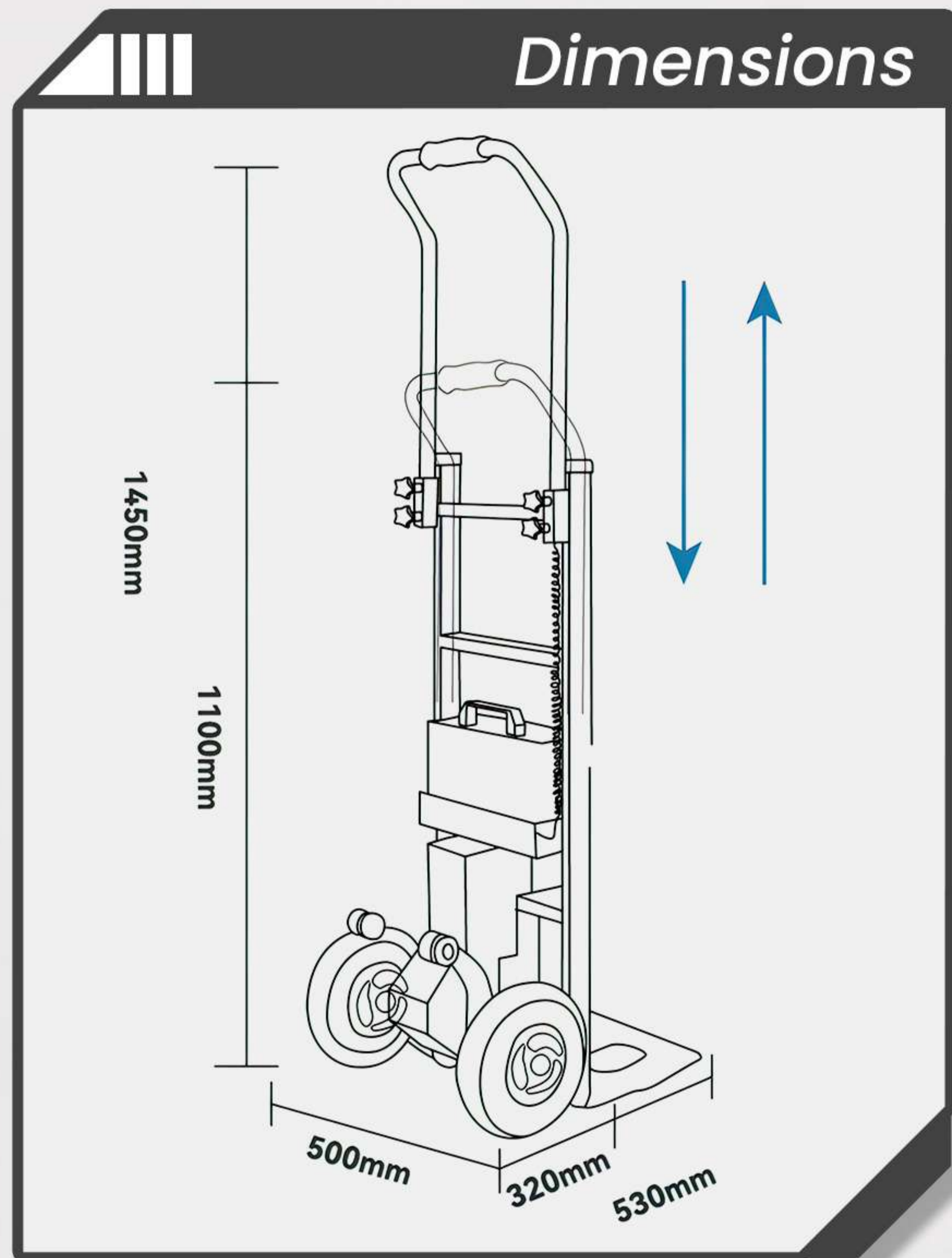

High Load
Capacity



Non-Slip
Wheels



Lightweight
And Durable

SPECIFICATION

Body material	Aluminum alloy	Battery capacity	8AH
Product weight	24kg	Endurance	1600 steps (continuous climbing with full load)
Battery weight	3kg	Handrail style	Scalable
Maximum load	200kg	Main wheel	10 inches
MAX climbing speed	50step/min	Maximum step height	230mm
Working voltage	48VDC	Minimum turning radius	500mm
Charging voltage	220VAC	Noise	<70db
Charging time	3H	Working ambient temperature	From -20°C to 50°C
Motor type	400W	Maximum size	1450*500*530mm
Battery type	Lithium battery	Minimum size	1100*500*300mm

STAIR CLIMBER POWERED

TYPE HPS202H-180

Effortlessly transport heavy items with the motorized Stair Climber, offering smooth, safe, and efficient operation for commercial and industrial use. Features include strong motor assistance, non-slip wheels, and a reliable braking system.

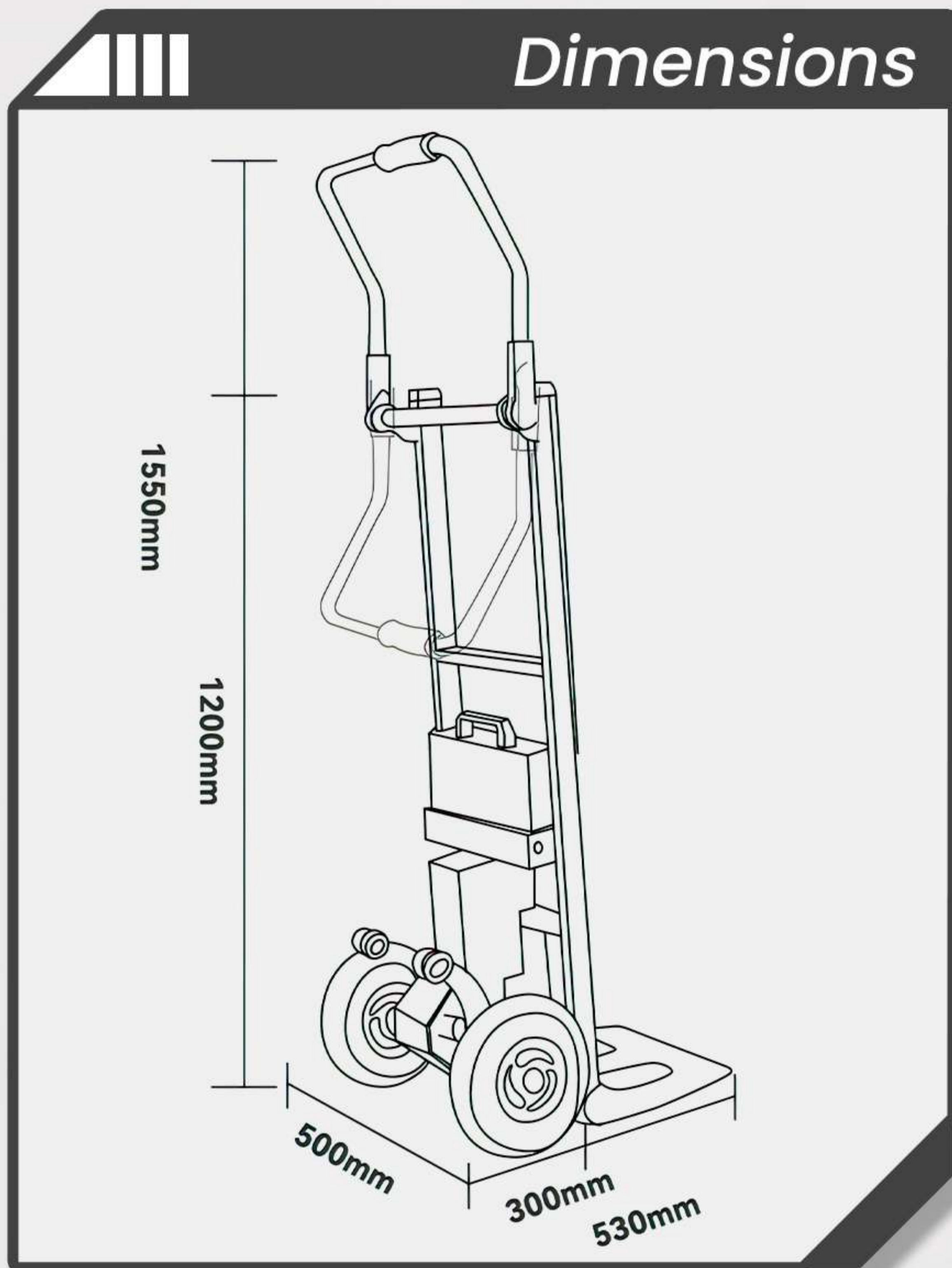

High Load
Capacity



Non-Slip
Wheels



Lightweight
And Durable

SPECIFICATION

Body material	Aluminum alloy	Battery capacity	8AH
Product weight	24kg	Endurance	1600 steps (continuous climbing with full load)
Battery weight	3kg	Handrail style	Foldable
Maximum load	200kg	Main wheel	10 inches
MAX climbing speed	50step/min	Maximum step height	230mm
Working voltage	48VDC	Minimum turning radius	500mm
Charging voltage	220VAC	Noise	<60db
Charging time	3H	Working ambient temperature	From -20°C to 50°C
Motor type	400W	Maximum size	1550*500*530mm
Battery type	Lithium battery	Minimum size	1200*500*300mm

STAIR CLIMBER POWERED

TYPE HPS215X-180

Effortlessly transport heavy items with the motorized Stair Climber, offering smooth, safe, and efficient operation for commercial and industrial use. Features include strong motor assistance, non-slip wheels, and a reliable braking system.

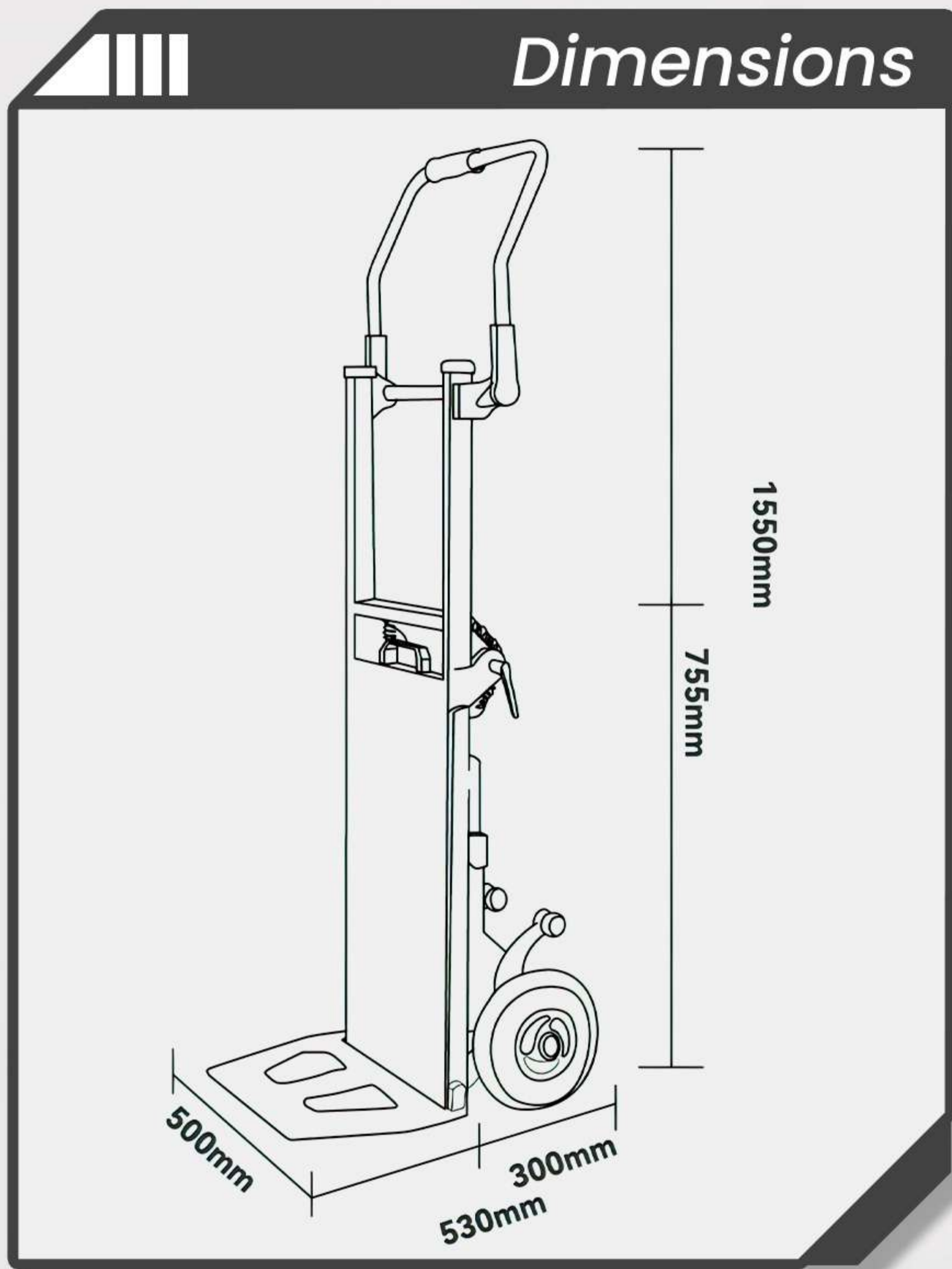

High Load
Capacity



Non-Slip
Wheels



Lightweight
And Durable

SPECIFICATION

Body material	Aluminum alloy	Battery capacity	8AH
Product weight	25.7kg	Endurance	1600 steps (continuous climbing with full load)
Battery weight	3kg	Handrail style	Foldable
Maximum load	200kg	Main wheel	10 inches
MAX climbing speed	50step/min	Maximum step height	230mm
Working voltage	48VDC	Minimum turning radius	500mm
Charging voltage	220VAC	Noise	<60db
Charging time	3H	Working ambient temperature	From -20°C to 50°C
Motor type	400W	Maximum size	1550*500*530mm
Battery type	Lithium battery	Minimum size	755*500*300mm

STAIR CLIMBER POWERED

TYPE HPS231-60

Effortlessly transport heavy items with the motorized Stair Climber, offering smooth, safe, and efficient operation for commercial and industrial use. Features include strong motor assistance, non-slip wheels, and a reliable braking system.

Dimensions

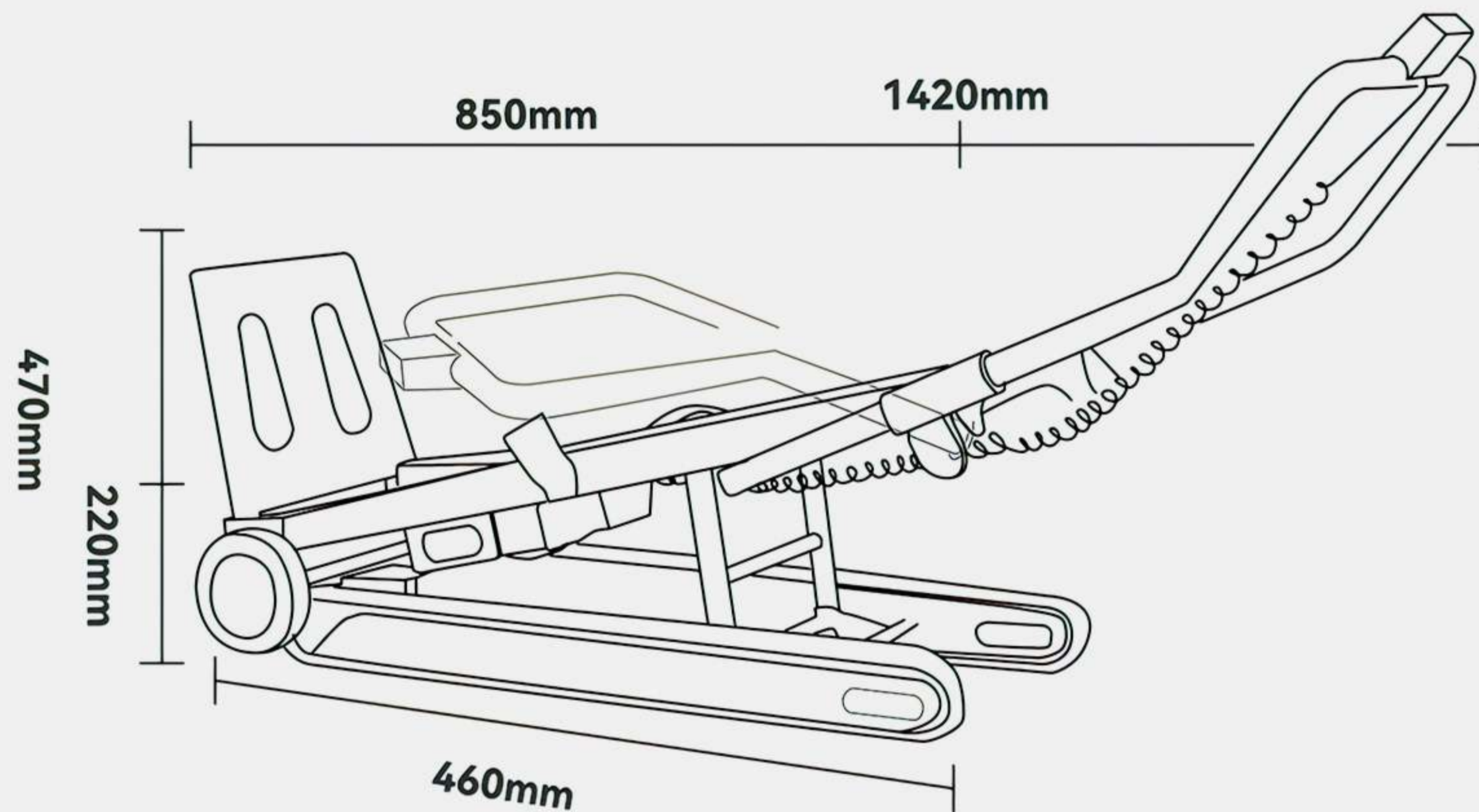

High Load
Capacity



Non-Slip
Wheels



Lightweight
And Durable



SPECIFICATION

Model	HPS231-60	Battery type	Lithium battery
Body material	Aluminum alloy	Battery capacity	5.2AH
Product weight	14kg	Endurance	1200 steps (continuous climbing with full load)
Battery weight	1kg	Handrail style	Foldable
Maximum load	80kg	Main wheel	5 inches
MAX climbing speed	55step/min	Minimum turning radius	500mm
Working voltage	24V	Noise	<60db
Charging voltage	220VAC	Working ambient temperature	From -20°C to 50°C
Charging time	2H	Maximum size	1420*460*470mm
Motor type	80W	Minimum size	850*460*220mm

STAIR CLIMBER BOTTLED WATER

TYPE HB247-60

Designed for easy transport of large water bottles on stairs, this climber ensures secure, spill-free delivery. Ergonomic handles and secure fastening make it perfect for residential and commercial use.

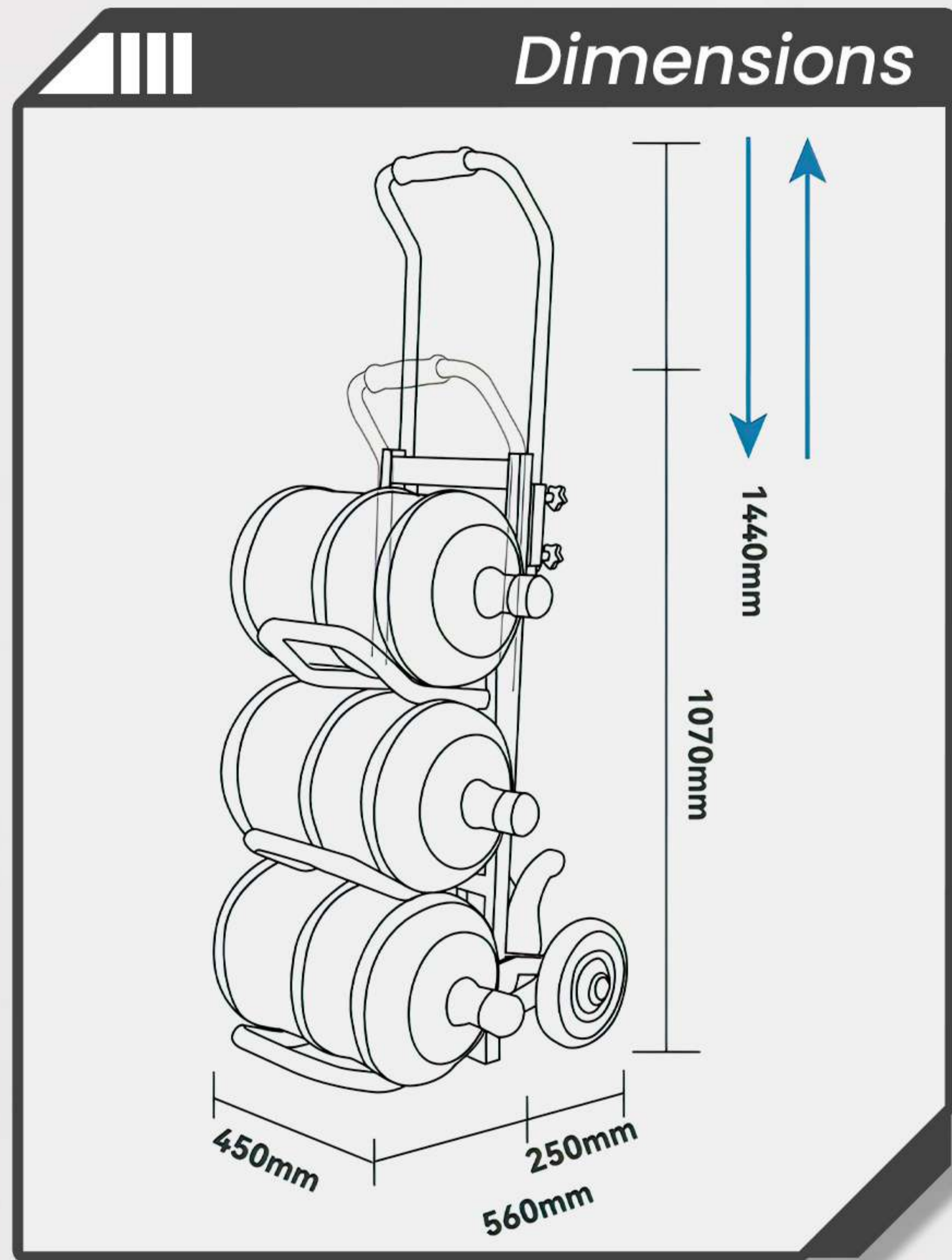

High Load
Capacity



Non-Slip
Wheels



Lightweight
And Durable

SPECIFICATION

Body material	Aluminum alloy	Battery capacity	8AH
Product weight	16kg	Endurance	2600 steps (continuous climbing with full load)
Battery weight	3kg	Handrail style	Scalable
Maximum load	80kg	Main wheel	8 inches
MAX climbing speed	10-65step/min	Maximum step height	210mm
Working voltage	48VDC	Minimum turning radius	500mm
Charging voltage	220VAC	Noise	<60db
Charging time	3H	Working ambient temperature	From -20°C to 50°C
Motor type	400W	Maximum size	1400*450*560mm
Battery type	Lithium battery	Minimum size	1070*450*250mm

STAIR CLIMBER BOTTLED WATER

TYPE HBS201-200

Designed for easy transport of large water bottles on stairs, this climber ensures secure, spill-free delivery. Ergonomic handles and secure fastening make it perfect for residential and commercial use.

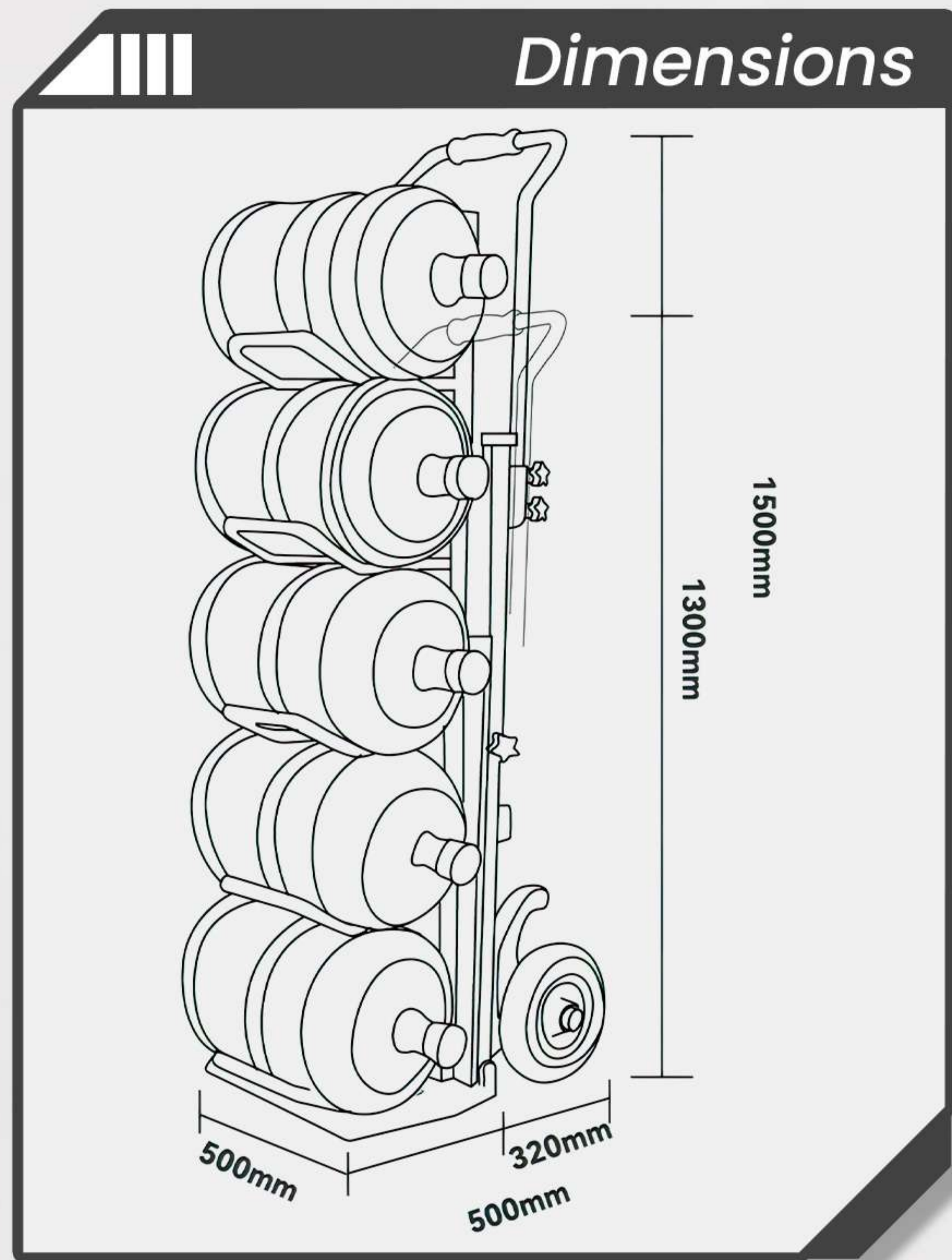

High Load
Capacity



Non-Slip
Wheels



Lightweight
And Durable

SPECIFICATION

Body material	Aluminum alloy	Battery capacity	8AH
Product weight	24kg	Endurance	2200 steps (continuous climbing with full load)
Battery weight	4kg	Handrail style	Scalable
Maximum load	200kg	Main wheel	10 inches
MAX climbing speed	10-65step/min	Maximum step height	230mm
Working voltage	48VDC	Minimum turning radius	500mm
Charging voltage	220VAC	Noise	<60db
Charging time	3H	Working ambient temperature	From -20°C to 50°C
Motor type	400W	Maximum size	1500*500*500mm
Battery type	Lithium battery	Minimum size	1300*500*320mm

STAIR CLIMBER BOTTLED WATER

TYPE HPST201-200

Designed for easy transport of large water bottles on stairs, this climber ensures secure, spill-free delivery. Ergonomic handles and secure fastening make it perfect for residential and commercial use.

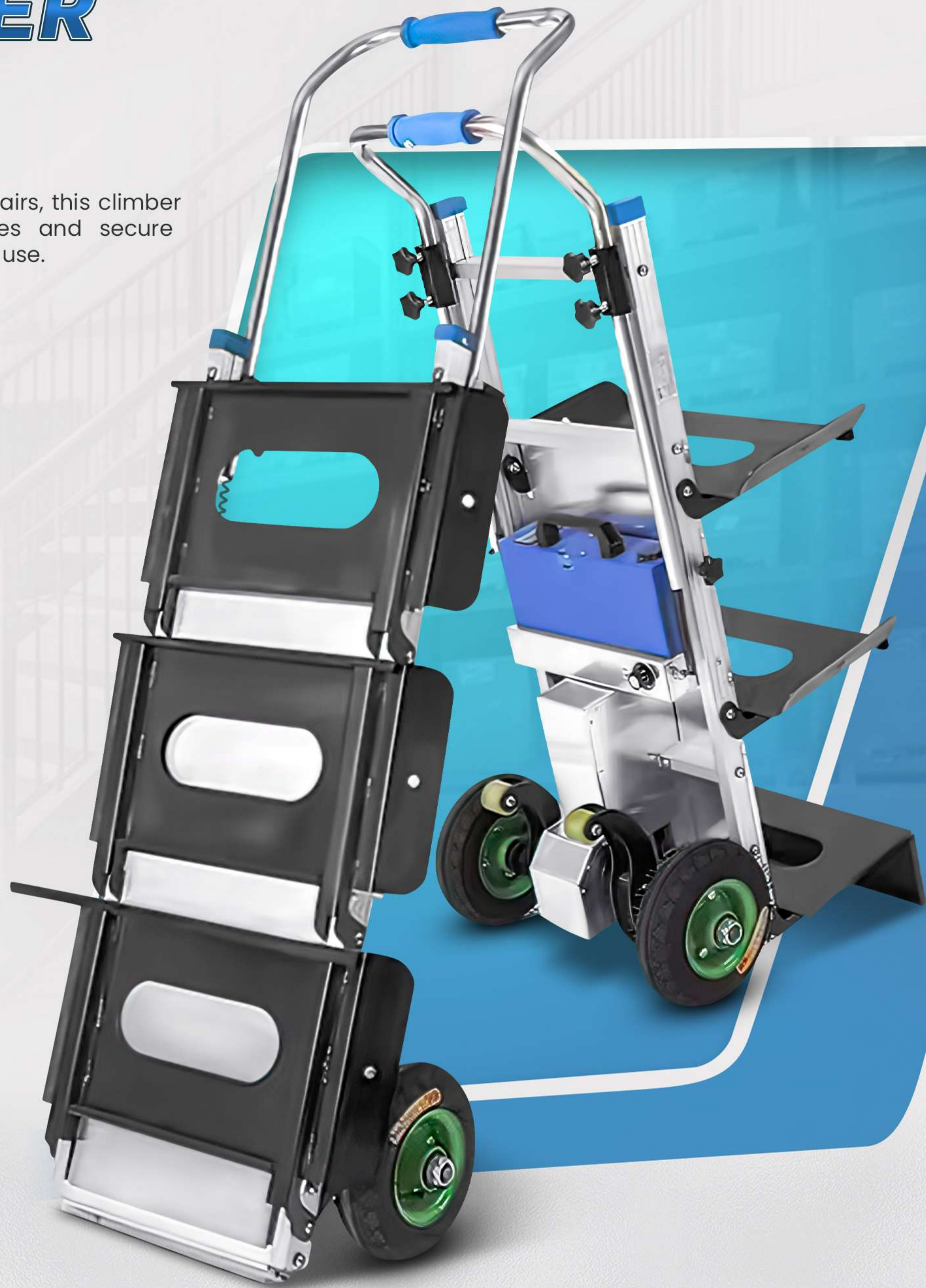
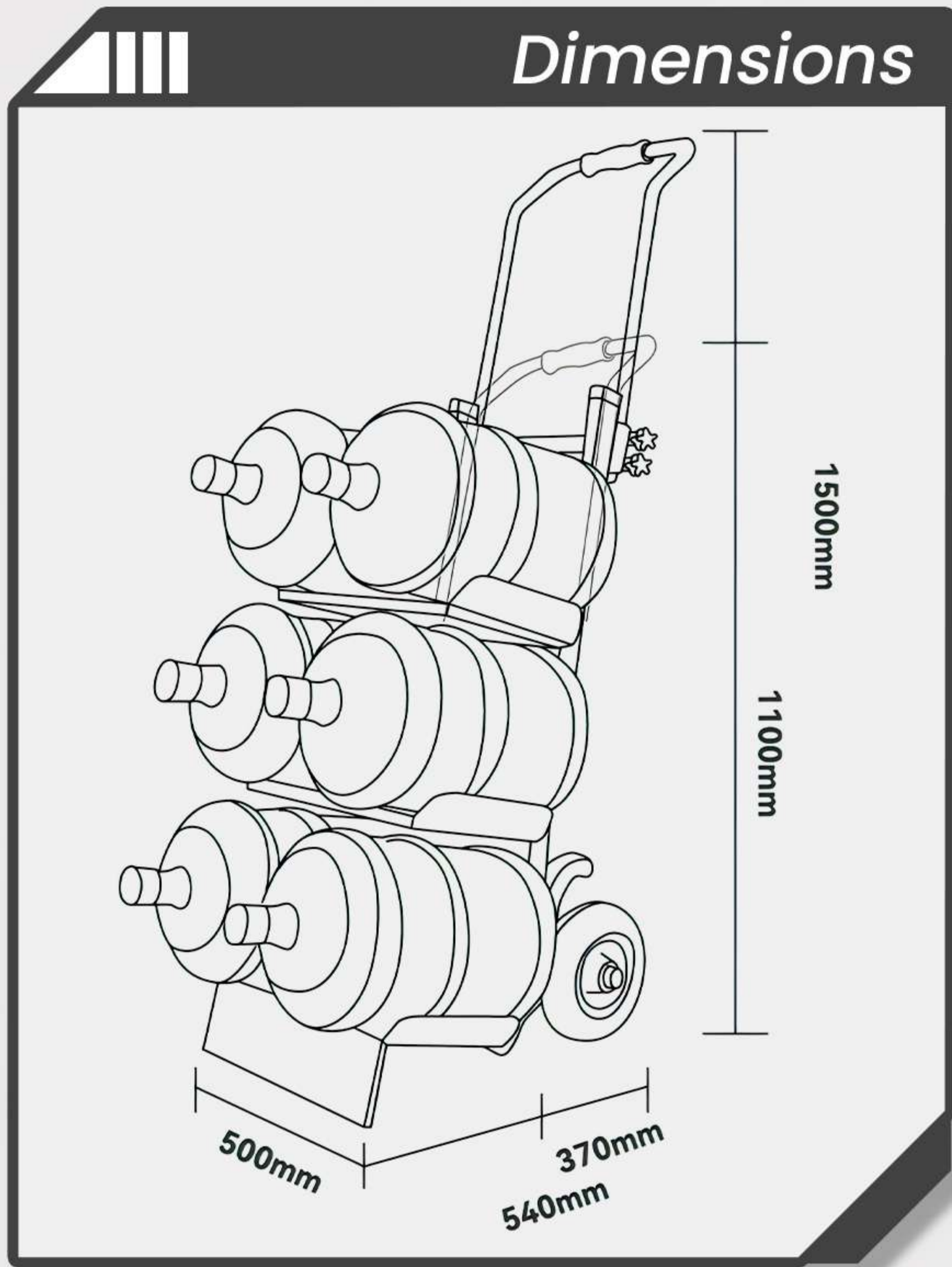

High Load
Capacity



Non-Slip
Wheels



Lightweight
And Durable

SPECIFICATION

Body material	Aluminum alloy	Battery capacity	8AH
Product weight	31kg	Endurance	1800 steps (continuous climbing with full load)
Battery weight	3kg	Handrail style	Scalable
Maximum load	200kg	Main wheel	10 inches
MAX climbing speed	10-65step/min	Maximum step height	230mm
Working voltage	48VDC	Minimum turning radius	500mm
Charging voltage	220VAC	Noise	<60db
Charging time	3H	Working ambient temperature	From -20°C to 50°C
Motor type	400W	Maximum size	1500*500*540mm
Battery type	Lithium battery	Minimum size	1100*500*370mm

STAIR CLIMBER

FLAT PUSH BRACKET

TYPE HPB203A

The Flat Push Bracket is an essential accessory for your Stair Climber, designed to provide additional support when transporting flat, wide items like boxes or panels. It easily attaches to your climber, offering a stable and secure platform that evenly distributes weight, reducing the risk of slippage or imbalance during transport. This bracket is perfect for enhancing the versatility of your Stair Climber, making it ideal for moving a variety of flat items with ease.



**Durable
Build**



**Enhanced
Safety**



**Easy
Attachment**



STAIR CLIMBER

GAS CYLINDER LOCK

TYPE HGC203C

The Gas Cylinder Lock is a crucial safety accessory for transporting gas cylinders with your Stair Climber. This lock securely holds the cylinder in place during transport, preventing dangerous shifting or rolling on stairs. Designed with robust materials and an easy-to-use locking mechanism, it ensures that your gas cylinders are safely and securely transported, providing peace of mind in both residential and commercial settings.



Enhanced
Safety



Durable
Build



Easy
Attachment

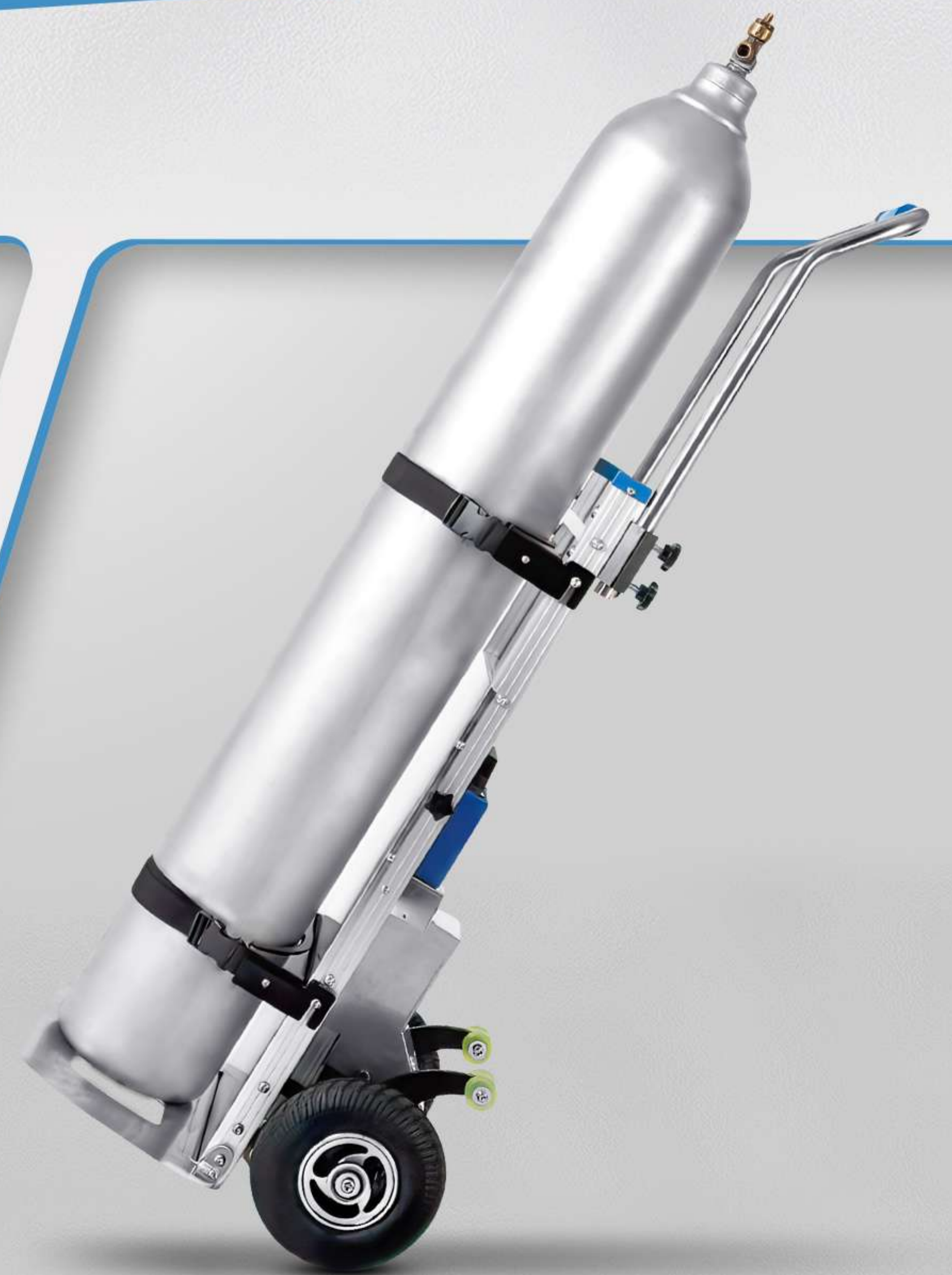

STAIR CLIMBER

BRAKE

TYPE HB203B

The Stair Climber Brake accessory is designed to enhance control and safety during transport on stairs. This reliable braking system allows users to easily engage and disengage the brake, ensuring that heavy loads remain stable during transport. Whether you're navigating steep or narrow stairs, the brake accessory provides the extra security needed to prevent accidents and ensure smooth, controlled movement of your Stair Climber.



Durable
Build



Enhanced
Safety



Easy
Attachment



Reliable
Control



INDOTARA®

PT. INDOTARA PERSADA

Our Marketing Office and After Sales Service Center

Head Office

50/F, Menara BCA Grand Indonesia
Jl. M.H. Thamrin No.1
Jakarta Pusat 10310
021 - 5011 2224
dsme@indotara.id



Semarang Office

Wisma HSBC Lt. 6 Suite 609
Jl. Gajah Mada No.135
Semarang, Jawa Tengah 50134
024 - 40 300 889
smg.dsme@indotara.id



Marketing Office

APL Tower 6th Floor No. 6 Central Park,
Jl. Letjen S. Parman Kav 28,
Jakarta Barat - 11440
021 - 5011 2224
dsme@indotara.id



Medan Office

Sutomo Tower Lantai 5H
Jl. Sutomo Ujung No.28,
Kota Medan, Sumatera Utara 20235
061 - 50 300 592
mdn.dsme@indotara.id



Graha Indotara

Millenium Industrial Estate
Jl. Millenium 22 Blok R3 No. 1
Cikupa, Tangerang - Banten 15720
021 - 5011 2224
dsme@indotara.id



Makassar Office

Fajar Graha Pena Lt. 5
Jl. Urip Sumoharjo No. 20,
Makassar - South Sulawesi 90234
021 - 5011 2224
mks.dsme@indotara.id



Bandung Office

Wisma HSBC Lt. 6 Suite B
Jl. Asia Afrika No. 116
Bandung, Jawa Barat 40112
021 - 5011 2224
bdg.dsme@indotara.id



Balikpapan Office

Panin Tower Lt. 8 - Grand Sudirman
Jl. Jendral Sudirman No.7 Klandasan Ilir,
Balikpapan Kota, Kalimantan Timur 76114
021 - 5011 2224
bpp.dsme@indotara.id



Surabaya Office

Japfa Indoland Center, Tower I Lt. 10/1008
Jl. Jendral Basuki Rahmat 129-137
Surabaya 60271
031 - 3360 1485
sby.dsme@indotara.id



Bali Office

Benoa Square Lt. 2
Jl. Bypass Ngurah Rai No. 21 A Kedonganan,
Kuta Badung - Bali Indonesia 80361
021 - 5011 2224
bali.dsme@indotara.id



Yogyakarta Office

Hartono Mall Yogyakarta Lt. 3
Kaliwaru, Condongcatur,
Sleman, Yogyakarta 55281
021 - 5011 2224
yog.dsme@indotara.id



Singapore Office

Marina Bay Financial Centre Tower 3
17F, 12 Marina Boulevard
Singapore - 018982
021 - 5011 2224
sing.dsme@indotara.id

